



# TSE & PSE Installation Manual

Navitas Technologies Ltd.  
C-855 Trillium Dr.  
Kitchener, Ontario N2R 1J9  
Canada  
Phone: (519) 725-7871  
Fax: (519) 725-1645  
[www.navitastechnologies.com](http://www.navitastechnologies.com)

# NAVITAS



Thank you for purchasing a Navitas Technologies motor controller. With proper installation and setting of the parameters, your Controller will give you years of trouble free operation, with a level of adjustability never before available.

**BEFORE YOU START** the installation, it is important to make sure that you have the right controller for your truck, as well as all of the associated components required. You must also ensure that the major components of the truck are in good shape.

Contactors should be checked for proper resistance to make sure that they do not draw more than 2 amps. Divide the rated voltage of the coil by the resistance to obtain the current draw in amps. As an example, a 36 volt coil should have a resistance of 18 ohms or more. If the coils draw more than 2 amps, they will need to be replaced.

Motors should be checked for shorts and ground faults, and cleaned up as necessary before proceeding with the installation of the new controller. Batteries should also get a thorough test to ensure that they are in good condition, with no dead cells or chassis leakage (ground faults).

Control wiring (harness) should be discarded, and power cables should be checked for breakage, bad crimps or broken insulation. **The Bypass Contactor (1-A) MUST BE DISCARDED** as the Navitas Technologies system does not require a Bypass.

Although the traction controller (TSE) and the hydraulic controller (PSE) can be used separately, maximum efficiency will be achieved by using them as a pair.

### **THE RIGHT CONTROLLER FOR THE JOB:**

As a rule, trucks of 4,000# capacity or less will use the TSE/PSE550 series, while the larger trucks will require the TSE/PSE1000 or TSE600 or PSE800 controllers. **All parallel dual motors trucks that require tight turn motor drop-out or reversal must use the TSE1000 Traction Controller.**

The PSE550P/600P/1000P series are used exclusively when the hydraulic controller is required to drive hydraulic solenoids (fixed or proportional) instead of using manual/mechanical spool valves to control the flow. This is normally reserved to the latest Reach type trucks (i.e. Raymond EASi Reach). The system interfaces directly to the control handle and eliminates the need for the complicated and expensive Vehicle Manager module. Call Navitas for more details.

Navitas Technologies also offers a full array of accessories such as accelerators, contactor assemblies, pots, diodes, etc.. Please ask your Dealer for more details.

### **READY TO GO:**

Once you have removed the old control system and the old harness, and thoroughly cleaned the area, find a suitable location for the controller(s) and the contactor assembly and drill and tap your mounting holes as per the template supplied with the controller. Install the controller(s) and the contactors, but save connecting the power cables until last, as it makes connecting the control wiring much easier.

**#1- TRACTION CONTROLLER with Standard Motor Configuration (TSE500/600/1000):**

The standard installation configuration is depicted in “Diagram #1” in the middle of this manual. Before connecting the harnesses to the controller(s) it is recommended to determine which of the optional inputs and outputs will not be used, and remove them from the harnesses. The **following connections must be made** for all installations:

White/yellow	forward switch input
White/grey	reverse switch input
White/red	SRO/seat switch
White/black	brake switch input (or tied to B+)
White/green	accelerator sweep input
White/blue	accelerator negative input
Orange	forward coil negative output
Grey	reverse coil negative output
Red	battery positive to Controller

The following connections are optional:

White/brown	speed limit #1 / Belly button switch input
White/orange	speed limit #2
White/purple	speed limit #3 / plug detect for TTR50
Blue	power steering timed negative output
Brown	pump contactor coil negative output **
Yellow	field weakening / “D” contactor negative output

\*\* When using a PC pump controller with the SE, the Brown output can be used as a “Line Contactor” driver. If you would like to do this you must contact Navitas for additional details.

Once you have determined which of the optional wires will not be used, they can be removed from the harness, and the harnesses can be connected to the controller.

As shown in “Diagram #1”, run a 16 gauge or larger wire from Battery Positive, through a 20 amp fuse to the key switch. Then run a similar wire from the switched side of the key to the Red wire on the controller. Run a separate wire from the switched side of the key to feed all of the coils, either directly or through their appropriate switches, again as per “Diagram #1”.

Then connect each of the control wires from the Navitas harness to their appropriate input or output. This concludes the control wiring installation.

**CABLE CONNECTIONS:**

“A1” from motor	Bar “A” on Navitas Controller
“A2” from motor	Normally Closed side of contactors + “AF” bar on Navitas
“S1” + “S2” from motor	Wipers on contactor assembly
“F” bar on Navitas	Normally Open side of contactors
“B+” and “B-“ on Navitas	Battery Positive and Negative

**#2- TRACTION CONTROLLER with DUAL MOTORS in PARALLEL (TSE1000 only):**

This connection method is the preferred way of installing a dual motors system with tight turn inside wheel drop-out. Even if your motors are presently connected in series, this method can be used as long as the controller output is set to 50% with the ProBit after installation.

Should you wish to install your motors in series, please refer to the Application Note #3 (D Contactor) in the Navitas Service and Product manual, or download the Note from our Technical Support area on our Website at <http://www.navitastechnologies.com>

For systems that require tight turn inside wheel reversing instead of the standard drop-out only, please see the TTR50 installation procedure on the next page.

The procedure for the control wiring is the same as in the Standard Configuration except for the following (see "Diagram #2" for this installation):

- Orange from the Navitas                      Both forward contactors negative output
- Grey from the Navitas                      Both reverse contactors negative output
- Yellow from the Navitas                    Negative "D" contactor output

- Battery positive to the directional contactor coils is run through the respective right and left turn switches, and must be fitted with blocking diodes (Diagram #2)
- All directional contactors must be fitted with suppressors.

**CABLE CONNECTIONS:**

A large external plugging diode must be installed in the left motor circuit (Diagram #2). This diode can usually be re-used from your old system. Check the diode for leaks and for proper polarity, as in some systems identical looking diodes may have different polarities. The CATHODE must be connected to the bar "A" on the Navitas controller.

A "D" contactor must be installed in the circuit. In most instances the old Bypass (1-A) contactor can be used for this purpose.

- "A1" from both motors                      Bar "A" on Navitas Controller
- "A2" from left motor                        Normally Closed side of left contactors + one side of the "D" contactor + anode of the plugging diode.
- "A2" from right motor                        Normally Closed side of right contactors + other side of the "D" contactor + "AF" bar on the Navitas Controller
- "S1"+"S2" left motor                        Wipers on left contactor assembly
- "S1"+"S2" right motor                        Wipers on right contactor assembly
- "F" bar on Navitas                            Normally Open sides of both contactor assemblies
- "B+" + "B-" on Navitas                      Battery Positive and Negative

You are now ready to proceed with the ProBit setup of the system. Run the Auto Setup procedure as usual answering "YES" to the Dual Motors questions and "D" Contactor, and "NO" to the TTR50.

Detailed explanations of the functioning of the ProBit including all possible fault codes and settings of parameters are available in our download area at <http://www.navitastechnologies.com>

### #3- NAVITAS TTR50 INSTALLATION (TSE1000 only):

The cable connections for this setup are done exactly as for the Dual Motors set-up on page 3. The control wiring goes as follows:

The Navitas-TTR50 Tight Turn Reverser (TTR) allows a dual motor truck with the motors wired in parallel to reverse the direction of travel of the inside wheel during a tight turn as well as the standard drop out of the inside wheel.

There are two types of tight turn switch configurations. One configuration uses two switches in each direction as the wheel is turned (See Diagram #3). The first switch is wired to the “Drop” input and the second switch is wired to the “Rev” input. When the “Drop” switch is closed the inside wheel will cut out. When the “Rev” switch is closed as well, the inside wheel will reverse (**the “Drop” switch must be held closed for the “Rev” switch to work**).

**The second configuration has only one turn switch in each direction. You can either wire the turn switches only to the “Drop” inputs, resulting in drop out of the inside wheels during a tight turn, or you can wire the switches to their respective “Drop” and “Rev” inputs together to get reversing of the inside wheel during a tight turn. With this second configuration, make sure that the switches do not come in prematurely, as the response of the truck could be very severe if the motor reverses too soon.**

#### **The rest of the instructions apply to both configurations:**

Install the TTR in a convenient location (the top of the Navitas Controller is a good choice (using double faced tape) and wire exactly as shown in Wiring Diagram #3. Limit 1 and Limit 2 on the TTR are wired to the limit switch inputs B4 (wh/brn) and B3 (wh/org) on the TSE1000. Program the TSE1000 (with the ProBit) to have appropriate cutback speed levels for these limits. Limit 1 will be active when one of the “Drop” switches is closed and Limit 2 will be active when one of the “Rev” switches is closed. This can (and should) be used to slow the truck down in a tight turn.

The yellow wire from the controller (normally the field weakening contactor output) must be connected to D-Ctr-In on the TTR. Note: The Field Weakening Contactor will be programmed as a “D” Contactor during the “Auto Install” sequence of the ProBit.

The contactors are connected as per Diagram #3. There is a light labeled “Contactor Overcurrent” on the TTR. If a contactor draws more than 2A this will light up and the TTR will be disabled. The only way to reset is to turn the key off and back on again.

The “A” input on the TTR gets connected to the “A” bar of the controller, and the “AF” input of the TTR must be connected to the **ANODE** side of the external plugging diode. Also the “Plug Dt.” on the TTR must be connected to the B2 input of the Navitas Controller (White/Purple wire).

Only the lift contactor needs to be suppressed externally. Do not use blocking diodes on the directional coil outputs as you would in a dual motor installation without a TTR50.

Wire B+ to the TTR from the key switch. Connect “B-“ from the TTR box **directly** to the B- bar on the SE.

Finally, run the “Auto Install” procedure on the ProBit, answering “YES” when the ProBit asks if you are doing a dual motor installation, and “YES” to the TTR50 question.

#### #4- HYDRAULIC (PUMP) CONTROLLER (PSE550/800/1000)

The standard installation configuration is depicted in “Diagram #4” in the middle of this manual. Before connecting the harness to the controller it is recommended to determine which of the optional inputs will not be used, and remove them from the harness. **The following connections must be made for all installations:**

White/yellow	SRO / Seat Switch
White/grey	Battery negative or third party BDI

The following connections are optional \*\*:

Red	B+ (used only if the PC is not connected to an SE)
White/red	Level switch #1
White/brown	Level switch #2
White/orange	Level switch #3
White/purple	Level switch #4
White/green	Accelerator sweep input
White/blue	Accelerator negative input
White/black	Not used

\*\* At least one of the level switches OR the accelerator must be used.

#### CABLE CONNECTIONS:

“B+” and “B-“	on Navitas Battery Positive and Negative
“A”	on Navitas Armature terminal on motor
“F”	on Navitas Field terminal on motor ***

\*\*\* Reversing “A” and “F” on a standard series wound motor has no effect. However, if the pump motor is of the permanent magnet type, reversing the cables will reverse the direction of rotation.

You are now ready to set up your controller with the ProBit. Please note that unlike in the case of the traction controller, the limit switches are prioritized from 1 to 4 (1 overrides 2, 2 overrides 3, etc..).

#### #5- ENHANCED HYDRAULIC CONTROLLER (PSE550/800/1000P)

The PSE550/800/1000P series of controllers is a very sophisticated control system designed to interface to an integrated control joystick and to run all of the fixed and proportional hydraulic solenoids found in the newer stand-up reach and straddle type trucks.

Unlike the standard PC, the PC+ has a set of five outputs to drive these solenoids. These outputs can be configured to any voltage up to battery voltage, fixed or proportional and can be mapped to a single function or to a bi-directional output in response to the direction and amount of travel of the lift accelerator pot. This controller also supports “on-demand” power steering when steering is achieved through the main hydraulic motor and a flow priority valve.

Diagram #5 shows a typical installation with the TSE and the PSE-P controllers. Please note that although the inputs pre-determined, outputs can be connected at random to their solenoids since they will be mapped and configured later with the ProBit.

Control connections for the PC+:

White/yellow	SRO / seat switch
White/green	accelerator sweep input
White/blue	accelerator negative input
White/grey	battery negative or third party BDI
White/red	bi-directional function #1 (reach)
White/brown	bi-directional function #2 (tilt)
White/orange	bi-directional function #3 (aux.)
White/purple	optional on-demand steering input

The five output wires (solid colors) can be connected to any solenoids as their functions will be mapped with the ProBit later.

Cable connections are identical to the standard PC installation.

To setup the system, first proceed to the normal set-up of the TSE and PSE with the ProBit. See the ProBit section of this manual. Then go into the <SETUP><CONTACTORS><PC+ COILS> to adjust voltage and map functions for the outputs of the PSE-P.

#### #6- THE NAVITAS PROBIT

The Navitas Technologies ProBit is a combination Installation and Customizing tool as well as a very efficient diagnostics and trouble-shooting aid. It consists of simple pull-down menus arranged in four main groups:

A: MAINTENANCE	To look at the condition of your equipment
B: CUSTOMIZE	To adjust your personal parameters and settings
C: TROUBLESHOOT	To test, monitor or run diagnostics on your system
D: INSTALL	To install new components, or re-install existing ones

The most complete information and guide to the ProBit is available in the form of a Windows Help File from your Dealer or in the download area of our Website at <http://www.navitastechnologies.com>

This Help file is named “ProBit Faults & Settings Guide” and includes all of the faults that can be detected by the ProBit with an explanation of the problem and the most probable solutions. It also includes all of the possible settings of the parameters, the path to find the right menu, the factory defaults and some warnings about some of the most sensitive settings. The latest file covers ProBit version 1.41 and will be updated as new versions become available.

The ProBit itself can also be updated if required. Contact your Dealer or Navitas Technologies for more information if your ProBit complains that it does not recognize a new version of controller.

**N/B:** When using the ProBit with a Pump Controller (PSE550/800/1000) that is not connected to a Traction Controller (TSE550/600/1000) you must hold down the “A” and “B” buttons on the ProBit simultaneously prior to turning on the ignition key, and hold them until a small “M” appears in the corner of the screen.

From that point the ProBit can be used normally to adjust the PC controller.





**Setting your new Controller with the ProBit (continued):**

After verifying all of your connections (particularly B+ and B-) one last time, connect the battery. A small amount of arcing is normal the first time as you are charging the internal capacitors.

As you turn on the key, you should hear the directional contactors cycle once. This is normal as the controller is running diagnostics.

Plug in the ProBit, and go to the “Auto Install” sequence in the “Install” menu.

Proceed with the Auto Install right to the end while answering the questions on the screen as they come up. Should the ProBit find anything wrong in your installation along the way, it will abort the installation process and inform you of the fault that it has found.

After completing the installation procedure, go back to the CUSTOMIZE menu to set up the following parameters to suit your operation:

- Speed forward and reverse to suit the operation
- Acceleration forward and reverse to suit the operation
- Plugging strength forward/reverse to suit the operation (max. of 800 amps)
- Peak Current limit manufacturer limit x 2 (max. of 900 amps)
- Average Current limit manufacturer limit less 25%
- Peak Current limit Pump (PC only) to suit the operation (max. of 900 amps)
- Average Current limit Pump to suit the operation
- Contactor Pull-in Voltage rated voltage of the coils
- Contactor Hold Voltage  $\frac{3}{4}$  of rated voltage of the coils

If Field weakening is used, the parameters for the Pull-in and Drop-out of the contactor must be set. To determine the proper levels, go into <TROUBLESHOOT><MONITOR><MOTOR CURRENT> and drive the truck at full speed on a flat surface. Record the amperage used at that speed.

- Field Weakening Pull-in recorded amperage x 1.3
- Filed Weakening Drop-out Pull-in level x 2

If you wish to use the built-in Battery Discharge Interrupt system, go into <CUSTOMIZE> <PROTECTION> <BDI>

- BDI on/off turn on
- Cut-out level to suit operation (1.70 VPC = 1.160 specific gravity)

Should you experience any problems or have any questions during the installation or set-up procedures, do not hesitate to call and ask for help. Five minutes spent on the phone with us may save you hours of frustrations and troubleshooting later.

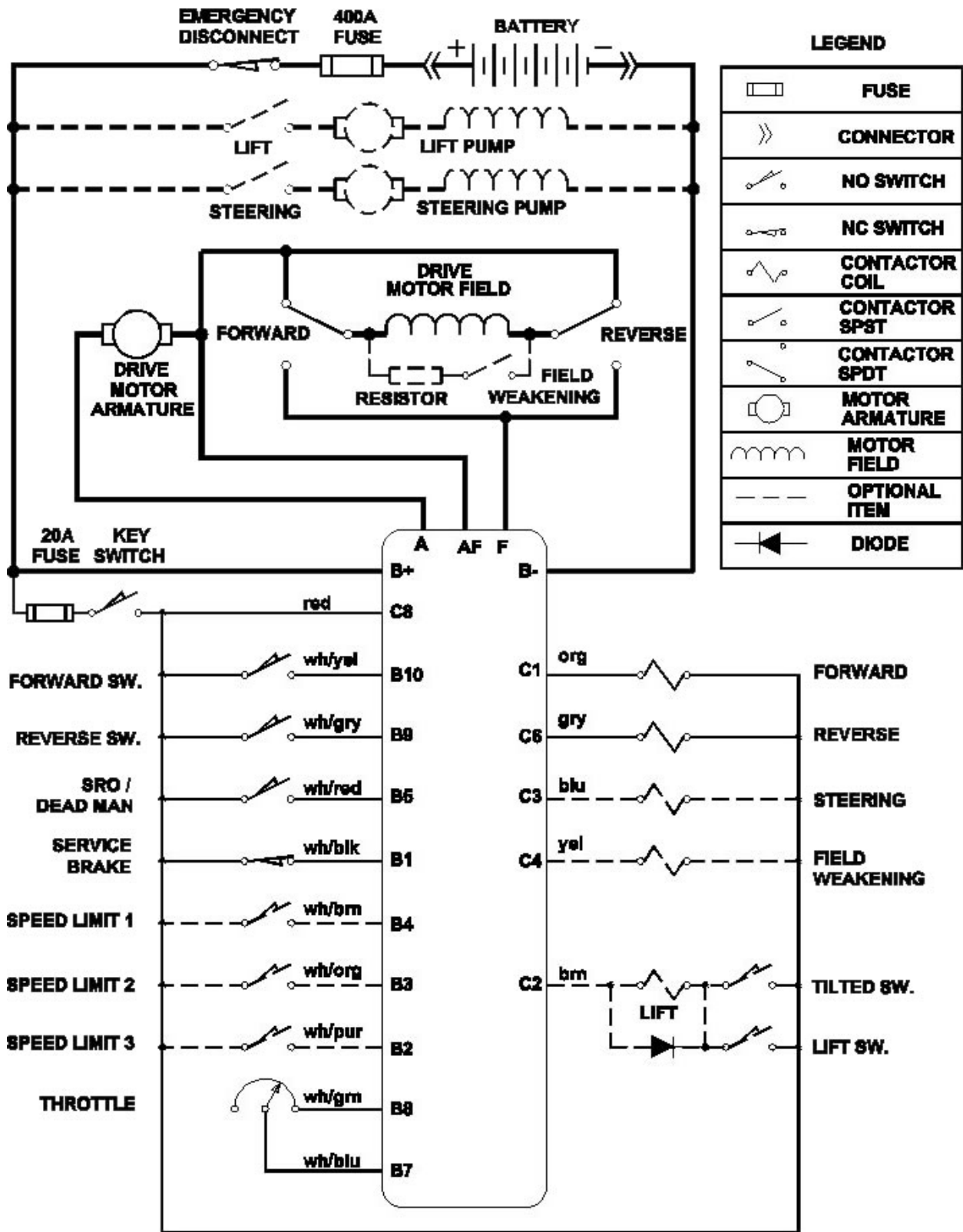

DIAGRAM #1

